

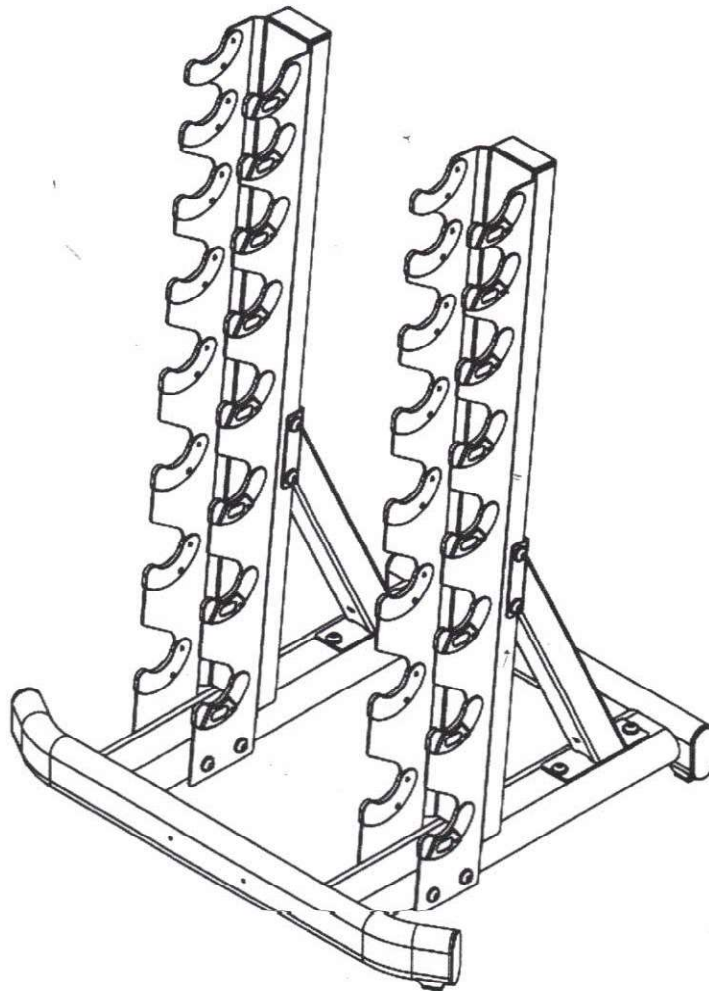

MODEL# RCK-SBSVD
8 pair Side by Side Vertical Dumbbell
Rack Manual



www.tagfitness.net

630-375-1500

EXPLODED DRAWING & PART LIST

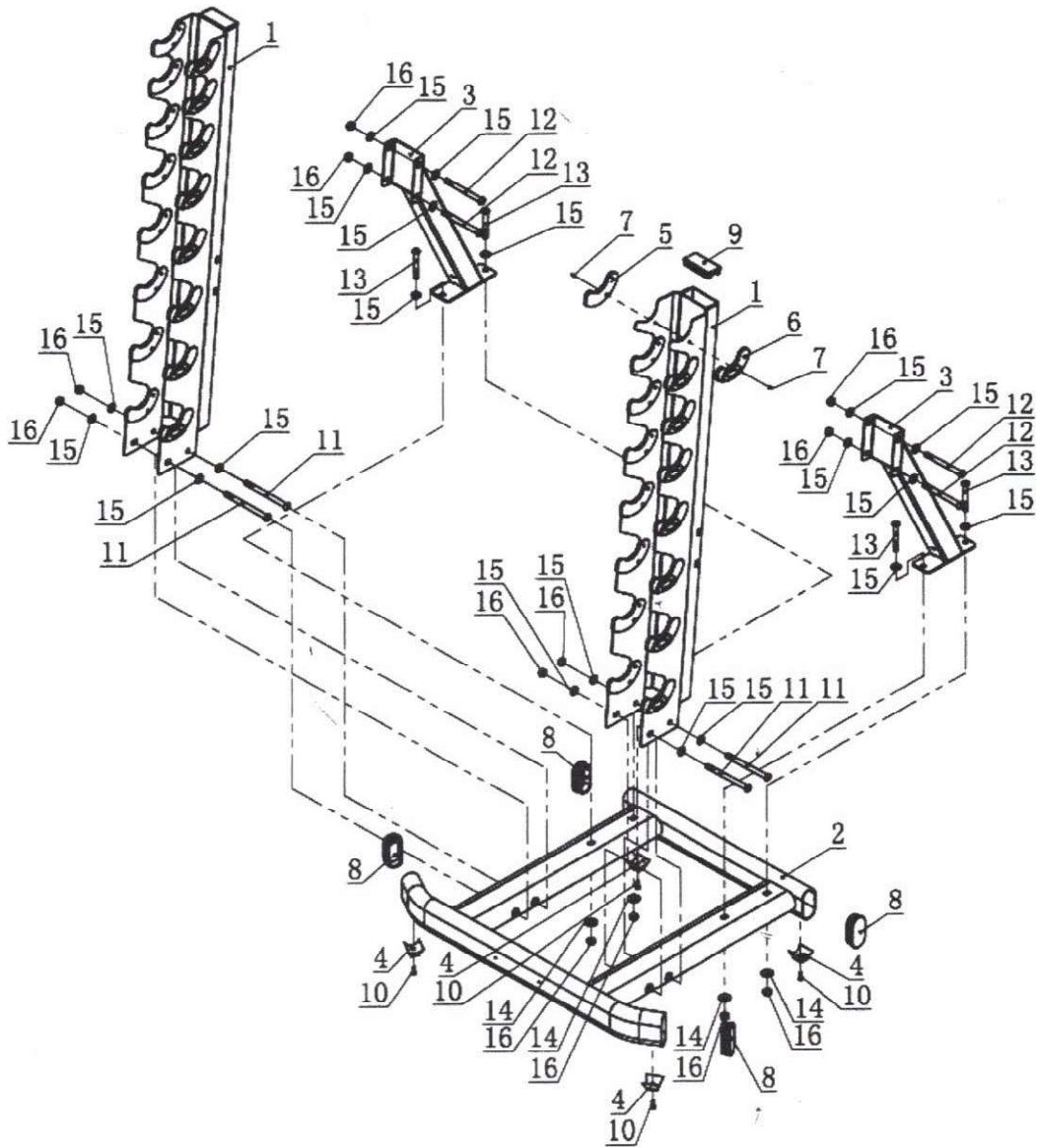

No.	Description	Qty	No.	Description	Qty
1	Vertical Frame	2	9	End Cap J40*80*2	2
2	Foot Frame	1	10	Cross Pan Screw M5*15	4
3	Back Support Frame	2	11	Hex Pan Bolt M10*125	4
4	Cushion PVC 40*35.3*20	4	12	Hex Pan Bolt M10*110	4
5	Left Cradle 95*10	16	13	Hex Pan Bolt M10*70	4
6	Right Cradle 95*10	16	14	Big Washer Ø10.6*Ø26*2	4
7	Pin Ø6*9.5	32	15	Flat Washer Ø11*Ø20*2	20
8	End Cap PT40*80*2	4	16	Nut M10	12

ASSEMBLY

STEP 1

Fix 2 Vertical Frame (1) onto Foot Frame (2), using 4 Hex Pan Bolt M10*125 (11), 8 Flat Washer $\text{Ø}11 \times \text{Ø}20 \times 2$ (15) and 4 Nut M10 (16).

Don't tighten the bolts.

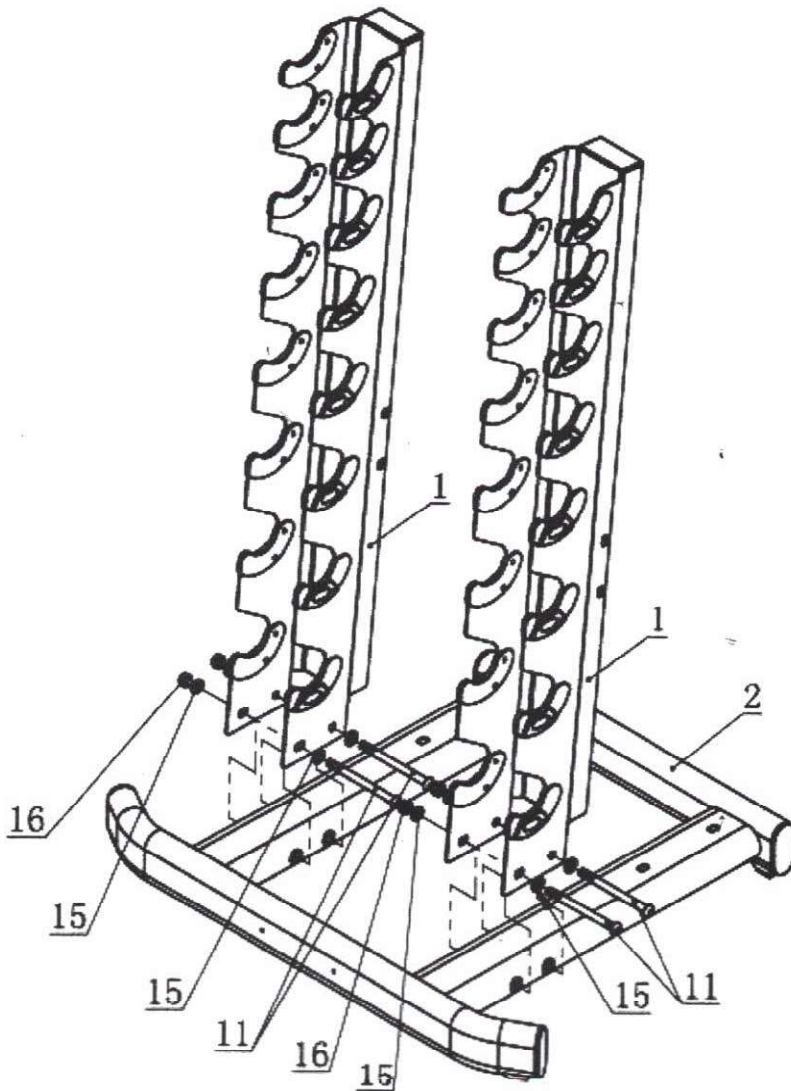

STEP 2

Install 2 Back Support Frame (3) onto Vertical Frame (1), using 4 Hex Pan Bolt M10*110 (12), 8 Flat Washer $\text{Ø}11 \times \text{Ø}20 \times 2$ (15) and 4 Nut M10 (16);

Install 2 Back Support Frame (3) onto Foot Frame (2), using 4 Hex Pan Bolt M10*70 (13), 4 Flat Washer $\text{Ø}11 \times \text{Ø}20 \times 2$ (15) and 4 Big Washer $\text{Ø}10.6 \times \text{Ø}26 \times 2$ (14) and 4 Nut M10 (16).

Tighten all bolts.

